

FSD

离心干燥机

Centrifugal dryer

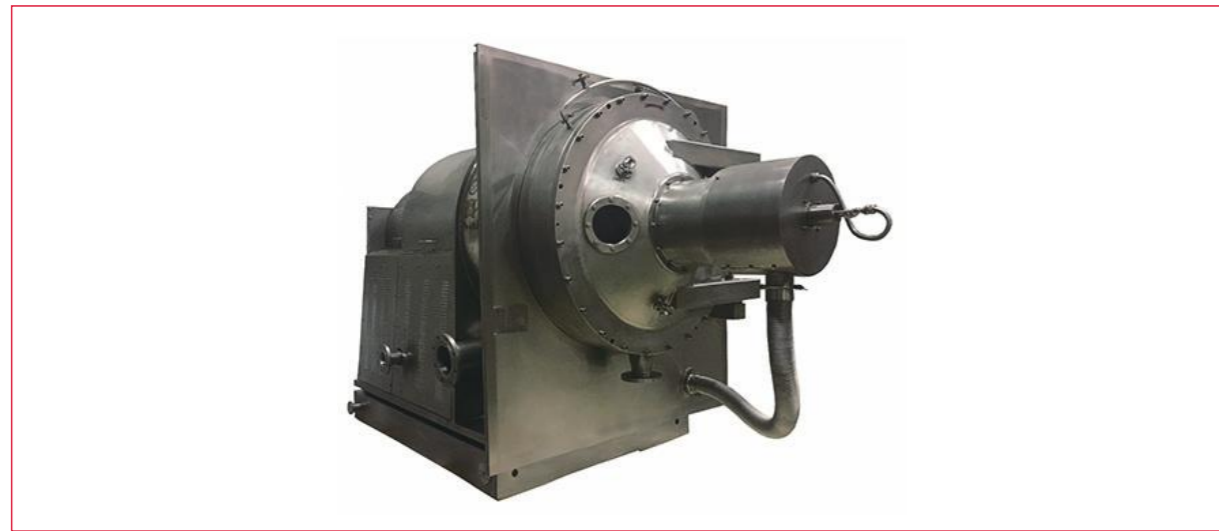

● 性能与用途

该机集分离、干燥、灭菌等多功能于一体，完美的密封系统，绝对的安全性，特别适用于高活性化合物、原料和医药中间体、剧毒产品、必须在无菌环境中生产的药剂、易氧化的物料等。

该机全套采用德国技术，生产全过程由德国专家驻厂指导、监督、检验，生产工人、工程技术人员由德国公司专业培训，关键部件由德国原装进口。

● 特点

- 1.一体化设计
- 2.无交叉污染
- 3.高效程序控制
- 4.多功能于一体
- 5.全自动控制系统
- 6.可靠性高
- 7.结构紧凑、占用场地小
- 8.适合蒸汽无菌场合使用
- 9.完善的在线检测和在线监控
- 10.无颗粒损坏
- 11.运行高度灵活

● 工作过程 Working process



● Properties and Uses

This machine integrate separating,drying, sterilization,with perfect seal system, absolute security and is particularly suitable on high potency compounds,pharmaceutical output stages,highly toxic products,application methods,agents that have to be manufactured in sterile environment and products sensitive to oxygen.

Based on German technology and with core components made in Germany,the whole producing is directed,supervised,inspected by German specialist,workers and engineers are trained by FIMA.

● Feature

- 1.One Apparatus
- 2.No Cross Contamination
- 3.High Containment
- 4.Total Discharge
- 5.Operation in versatile applications due to high process flexibility
- 6.Reliability
- 7.Compact Design
- 8.Sterile Design
- 9.Online Monitoring
- 10.No Particle Destruction
- 11.High Process Flexibility

● 反冲技术 Counter-pulse Technology

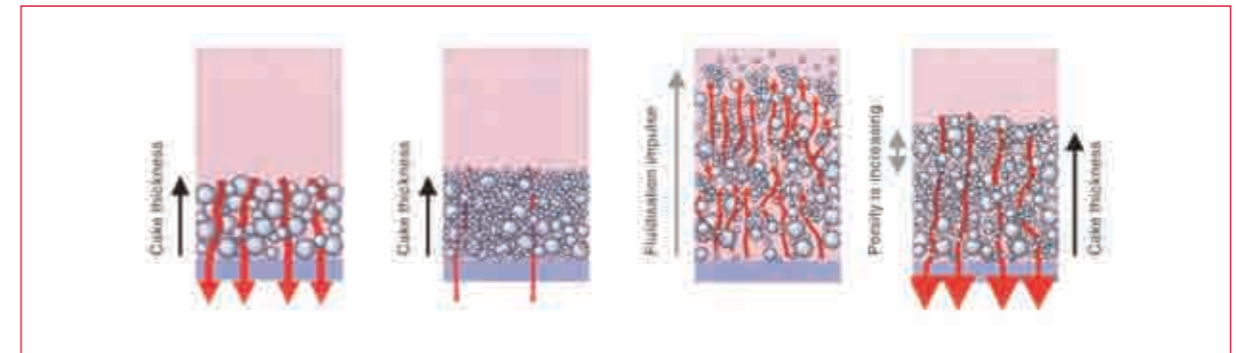

● 清洗和安全

特点

- 1.密闭清洗
- 2.可安装于洁净室
- 3.物料接触区域清洗简单方便
- 4.物料接触部位高质量抛光
- 5.可避免潜在污染
- 6.可用核黄素测试检查清洗效果
- 7.可通过挑战性试验验证

● Cleaning and security

Feature

- 1.Closed inner washing
- 2.Design for cleaning room
- 3.Easy and convenient washing for product contact parts
- 4.High quality polishing for product contact parts
- 5.Avoid potential contamination
- 6.Riboflavin test can be carried out for inspection of washing effect
- 7.Can be verified by challenge test

● 无菌级

特点

- 1.全密封外壳
- 2.可耐受蒸汽灭菌
- 3.内部无死角
- 4.无螺纹连接
- 5.全自动控制系统
- 6.可以有效地全自动运行SIP系统
- 7.可灭菌部件
- 8.特殊密封系统

● Sterile Version

Features

- 1.Hermetically closed housing
- 2.Housing for vapor sterilization
- 3.No washing dead angle inside
- 4.No screw connections
- 5.Full-automatic control systems
- 6.SIP system can be full-automatic and valid running
- 7.Sterilisable components
- 8.Special sealing systems



FSD

离心干燥机

Centrifugal dryer

● 技术参数 Technical parameters

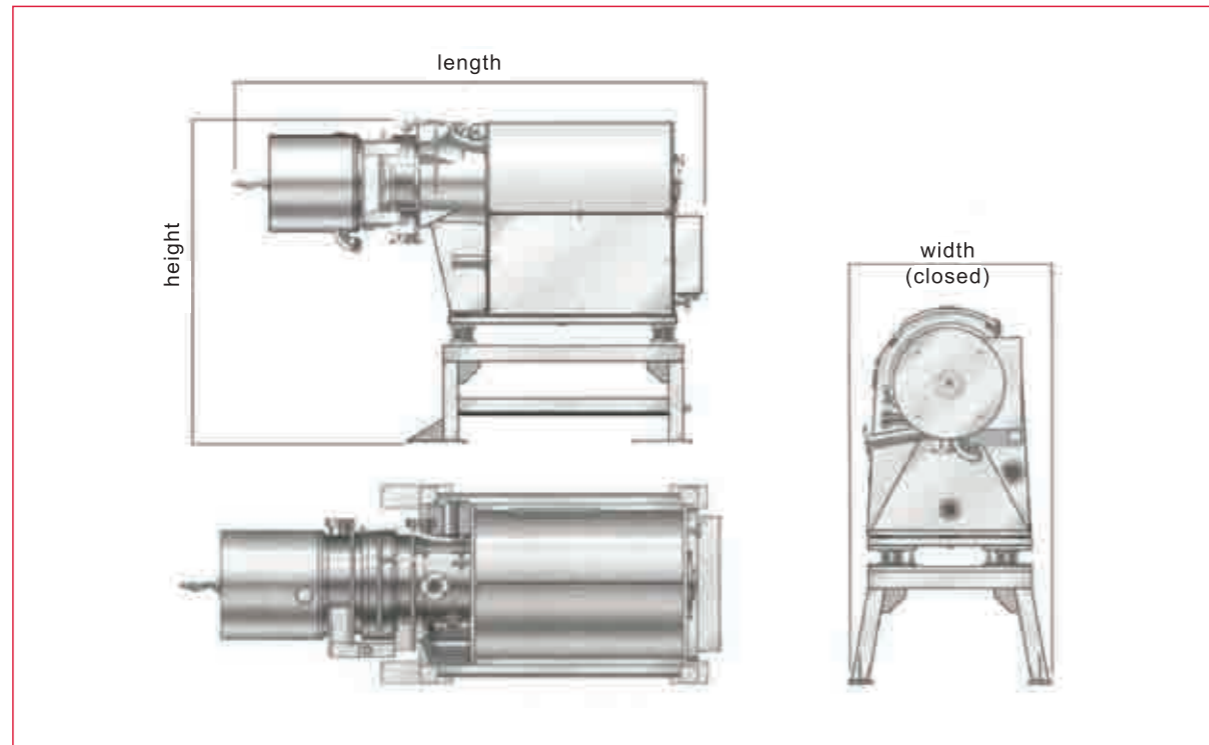

标准型号 Standard Model	FSD-400	FSD-600	FSD-800	FSD-1000	FSD-1300
转鼓直径Drum diameter(mm)	400	600	800	1000	1300
最大容积Filling volume,max (L)	20	63	125	235	800
过滤面积Filter area (m ²)	0.38	0.85	1.26	1.89	2.4
转速Rotating speed (r/min)	1640	1340	1160	1040	900
分离因素C-factor	601	602	602	605	600
长Length × 宽Width × 高Height(mm)	3200 × 1400 × 1700	3400 × 1600 × 1900	3900 × 1800 × 2400	4000 × 1800 × 2500	5600 × 2000 × 2800
重量Weight(Kg)	3500	4300	9500	11500	20500

● 应用行业

可广泛应用于化工、制药、食品、生物工程等行业，尤其适用于卫生要求高的医药、食品和特殊化工产品的生产。

● Application industry

It is widely used in Chemical, Pharmacy, Food, bioengineering industry and etc, especially suitable for the production of medicine, food and special chemical with high sanitary requirements.

