

YG

加压转鼓过滤机

Pressurization rotary drum filter



● 技术特点

1. 清洗循环

轻微挤压过的特定结构和密度的滤饼可以在一或几阶段清洗。旋转加压过滤器的这种设计保证了置换清洗使用最小量的清洗媒介。清洗液通过排液管排出，滤饼通过控制头(取决于选择的洗涤阶段)分离，假如必要的话循环回到过滤机。滤饼去水干燥和蒸发。

2. 滤饼卸料

从全自动过滤机操作或过滤机结构的使用寿命考虑，简单和完全的滤饼卸料很有必要。在旋转加压过滤器中，滤饼一般因为自身压力而掉落，假如黏着力阻止滤饼脱落，卸料进程会辅助以空气或气体反吹或通过刮刀机械卸料。过滤媒介通过顺水冲洗清洗干净。清洗结构可以使用最高25bar的压力，这使得从保留的方向把过滤器冲洗干净成为可能。

3. 连续运转

以前的加压过滤机差不多都是间隙式操作的，此机为连续式的，符合现代连续生产的要求，对于有害和有毒的固体和溶剂的过滤，显示出它独特的优势。

4. 完善的密封性

即使处理含甲醇、甲苯的滤浆时，或者必须采用挥发性溶剂作洗涤液，或者恶臭气味物料时，也不必担心泄漏。

5. 效率高

转鼓在回转一圈的过程中，同时完成过滤、滤饼洗涤、脱水干燥、卸料等一系列工序。

6. 滤饼的含湿率低

因为除了加压过滤外，还使用压缩空气、过热蒸汽或高温气体干燥滤饼，所以滤饼含湿率低。

7. 安全

该机的转速低，所以不会出现高速旋转机械的潜在危险。

● 概述与应用

加压转鼓过滤机是利用多孔性转鼓过滤介质，集洗涤、萃取、蒸发、干燥为一体，连续、全自动地截留液体与固体混合物中的固体颗粒而实现固液分离的密闭设备。可以快速地各类悬浮物料进行固液分离，连续出料，处理量大，脱水效果好，操作环境好，占地面积小，自动化程度高。产品设计上符合GMP、FDA规范要求。

● Summary and application

The pressurization rotary drum filter, integrating washing, extracting, evaporating and drying, is a piece of closed equipment that realizes solid-liquid separation after continuously and automatically retaining the solid granules in the liquid and solid mixture by using porous rotary drum filtering media. It can be used to quickly carry out solid-liquid separation of various suspension materials with such features as continuous discharging, high handling capacity, good dehydrating effect, good operating environment, low floor space and high degree of automation. The product design conforms to the requirements in GMP and FDA.

● Technical Features

1. Washing cycle

The filter cakes with slightly extruded special structure and density can be washed in one or several phases. This kind of design in the rotary pressurization filter ensures that the minimum amount of washing media is used for replacement washing. The washing liquid is discharged through the liquid discharging pipe. The filter cakes are separated through the control head (depending on the washing phase selected) and return to the filter if necessary. The filter cakes go for drying and evaporating.

2. Filter cake discharging

Taking into consideration the operation of the full-automatic filter or the service life of the filter structure, it is very necessary to carry out simple and complete filter cake discharging. In the rotary pressurization filter, the filter cake will drop due to its own gravity. If the sticking force prevents the filter cake from falling, back blowing by air or gas or mechanical discharging by the scraper can serve as an aid to the discharging process. The filtering media are washed clean in the downstream washing chamber. The washing mechanism can use a pressure up to 25bar, which makes it possible to wash the filter clean from the retaining direction.

3. Continuous running

The previous pressurization filters almost adopt intermittent operation, but this machine adopts continuous operation, which conforms to modern requirements for continuous production. It displays its unique advantages because it can filter harmful and poisonous solids and solvents.

4. Perfect sealing performance

There is no need to worry about leakage even when it is used for handling filter pulps containing methyl and alcohol methylbenzene, or when it is necessary to adopt the volatile solvents as the detergent, or when materials of stinky smell are handled.

5. High efficiency

The rotary drum simultaneously completes the procedures such as filtering, filter cake washing, dehydrating and drying, discharging, etc. When it turns a circle.

6. Low water content of filter cakes

The water content of filter cakes is low because the compressed air, superheated steam or high temperature gas are used to dry the filter cakes in addition to the pressurization filter.

7. Safety

The potential risk of high speed rotary machinery will not occur because the rotation speed of the machine is low. Dangerous high-speed rotating machinery.

● 主要应用行业

化工、石油、制药、轻工、食品、选矿、煤炭和水处理等行业。

● 工作原理

该机包含四个操作工况区域：过滤、洗涤、干燥、卸料。在过滤机缓慢旋转过程中，每一过滤单元都依次经过这四个区域，原始物料通过物料泵输送到过滤区域，压力过滤下，在滤网上形成滤饼，而滤液穿过过滤网经管路排放。洗涤区域，清洗液均匀喷洒在滤饼上，对滤饼进行强烈的洗涤作用。干燥区域，利用压缩气体或者过热蒸汽对滤饼进行干燥。卸料区域，通过在滤网背面反吹气体或者刮刀，将滤饼从单元室中刮出。转鼓旋转，每个过滤室也绕着轴线旋转，历经四个工作区，完成进料、过滤、洗涤、吹干、卸料等过程，周而复始，连续运行。

● 技术参数 Technical parameters

型号 Model	过滤面积(m ²) Filter area	转鼓直径(mm) Drum diameter	外形尺寸Dimensions (长×宽×高)(mm)	重量(Kg) Weight
YG-500	0.12	500	1000×900×1600	900
YG-750A	0.54	750	2000×1900×1800	3300
YG-750B	1.08	750	2300×1900×1800	3700
YG-1000A	1.44	1000	2500×2100×2200	5900
YG-1000B	2.16	1000	2700×2300×2200	7300
YG-1000C	2.88	1000	3300×2400×2500	8500
YG-1500A	3.20	1500	3100×2900×3200	11500
YG-1500B	4.32	1500	3700×3000×3200	14000
YG-1500C	5.76	1500	4000×3000×3200	17500
YG-2000	7.68	2000	4300×3400×4000	23500

● 结构图 Block Diagram

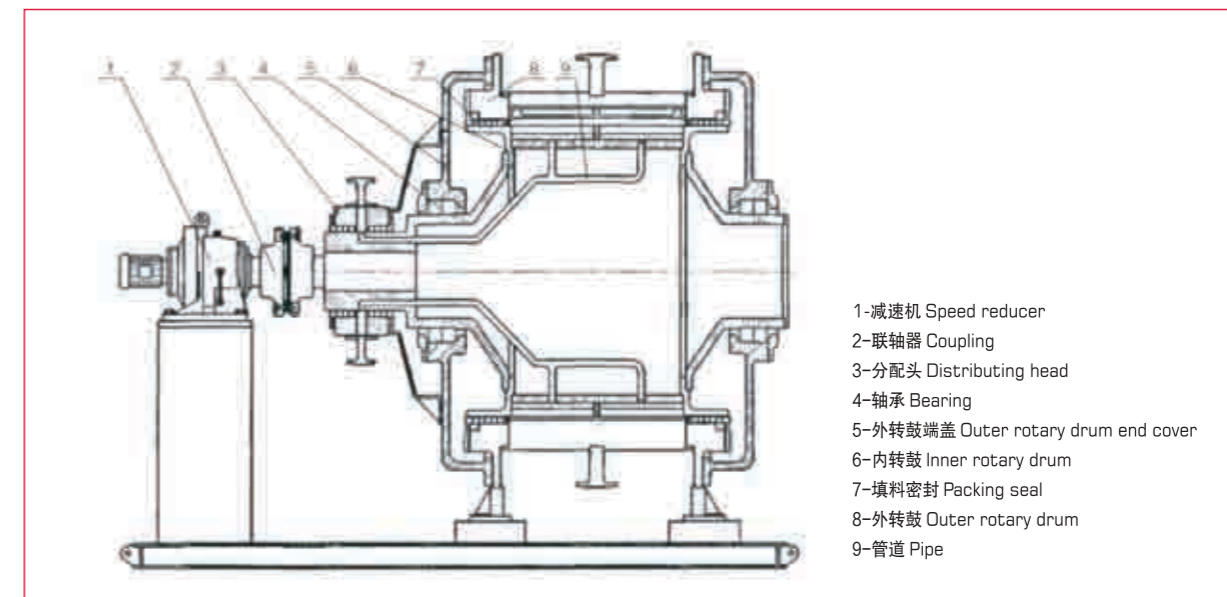

- 1-减速机 Speed reducer
- 2-联轴器 Coupling
- 3-分配头 Distributing head
- 4-轴承 Bearing
- 5-外转鼓端盖 Outer rotary drum end cover
- 6-内转鼓 Inner rotary drum
- 7-填料密封 Packing seal
- 8-外转鼓 Outer rotary drum
- 9-管道 Pipe